

# Color Stabilization of RGB LEDs in an LED Backlighting Example

## Application Note

---

### Introduction

In recent years, advancements in the area of optoelectronics due to the deployment of new semiconductor materials in the manufacturing of LEDs have permitted a diversity of color and increased levels of brightness to be achieved. LEDs and LED modules have recently been produced which can be used as a replacement for conventional light devices such as light bulbs and fluorescent lights in many application areas. Backlighting of TFT monitors, for example, was previously accomplished by the use of cold cathode fluorescent lamps (CCFLs). Due to the disadvantages of CCFLs regarding their white balance, spectral distribution and low mechanical strength, new bright light diodes have been considered as a replacement to CCFLs.

The technology used in TFT monitors, in which each pixel is comprised of red, green and blue sub pixels, offers a solution to backlight a display with these same primary colors. By mixing the primary colors in the proportions of 64% green, 8% blue and 28% red, a white light can be created. When considering various types of LEDs, the MultiLED emerges as an optimal light source for backlighting of displays, since the three colors can be mixed within the same device to create the white light.

Temperature variations and the influence of aging due to continual use have the effect of shifting the color spectrum of the backlight, however. In order to achieve a stable white balance, the temperature and aging characteristics of light diodes were investigated, and the influences on brightness and wavelength were

determined. Based on these results, a circuit was developed which provides a stable white balance of the backlight.

### MultiLED LATB G66x

For the backlight, the LATB G66x diode was used. This is a 6-lead MultiTOPLED®, a SMD light diode with three integrated semiconductor chips.

The red LED is produced with an InGaAlP material; the other two colors (blue and green) consist of an InGaN material.

By varying the currents for the individual chips, a white light can be achieved through the principle of additively mixing various colors.



Fig. 1: 6-lead MultiLED LATB G66x

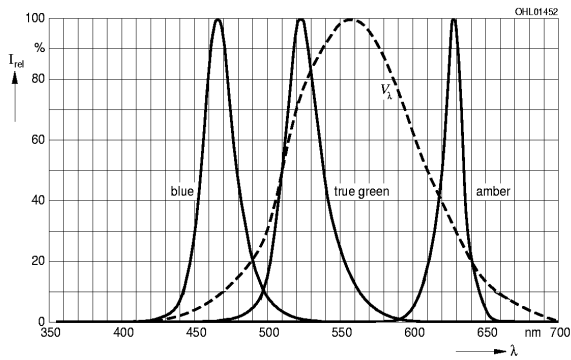

Fig. 2: Spectrum of the LATB G66x

## Temperature Characteristics

To examine the temperature dependency of the LEDs, the optical characteristics were specifically determined in the range of 0°C to 50°C. These limits were chosen to represent the typical ambient temperature range for the operation of TFT monitors.

### a) Luminous flux $\phi_v$

In figure 3, the luminous flux for three different chips is shown in relation to ambient temperature. For all three chips, a variation in luminous flux  $\phi_v$  can be observed, depending on the ambient temperature.

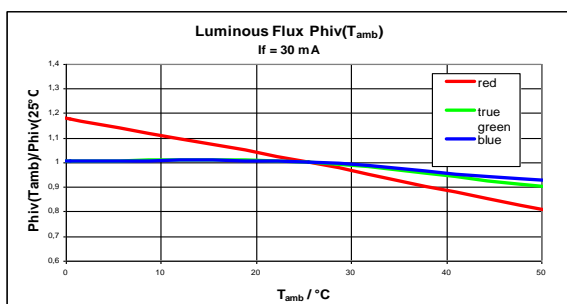

Fig. 3: Change in luminous flux  $\phi_v$  in relation to ambient temperature  $T_{amb}$

For the blue and green diodes, the luminous flux is reduced by approximately 10% over the range of 0°C to 50°C. The basically similar temperature characteristics of these chips can be attributed to the same chip technology employed.

The luminous flux for the red InGaAlP LED decreases linearly with increasing temperature. In the relevant temperature range, the intensity decreases by 40%.

The human eye is not able to recognize differences in brightness of less than  $\pm 15\%$ . This implies that the reduction in intensity due to temperature of the InGaN LEDs cannot be perceived by humans, and therefore does not need to be compensated. With red LEDs, however, the reduction is too large; compensation is necessary.

### b) Wavelength $\lambda_{Dom}$

Examination of the dominant wavelengths in relation to temperature showed similar characteristics to those of intensity. While the blue and green LEDs showed nearly stable temperature characteristics, the wavelength  $\lambda_D$  for the red LEDs increased proportionally with increased temperature.

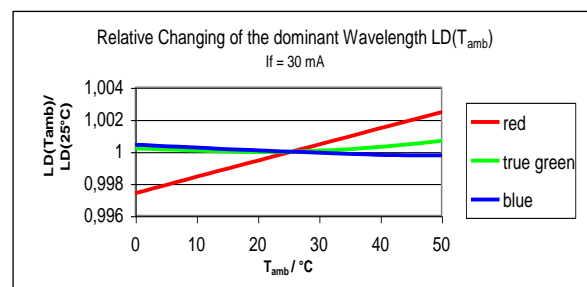

Fig. 4: Normalized representation of wavelength  $\lambda_{Dom}$  in relation to ambient temperature  $T_{amb}$

## Aging Characteristics

With increased operating time, the light intensity of LEDs decreases. When the intensity falls below half of its original value, the LED is considered to have reached the end of its operating life.

With all three chips, the influence of aging results in a reduction of light intensity. An exact prediction of the reduction in intensity for various chips is not possible, however, since this is strongly dependent on driving current and operational temperature.

In order to compensate for aging effects, the red:green:blue ratios must be kept constant. This means that the intensity of each color must be independently controlled.

## Compensation

In the following circuit, the LEDs are driven with a PWM signal. This provides an advantage over a DC supply voltage in that the brightness can be controlled by a constant current, and that disadvantageous wavelength variations due to effects induced by current fluctuations can be prevented. The radiation intensity and thus the brightness is dependent on the duty cycle of the signal. In order to prevent flickering, the frequency of the PWM signal should be greater than the refresh rate for a TFT monitor.

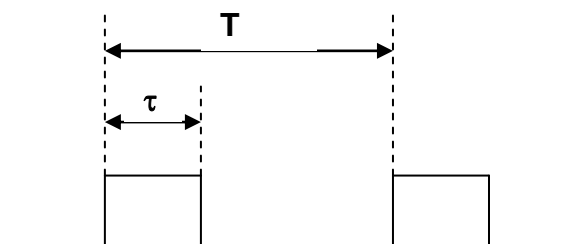

**Fig. 5: PWM signal**

**T: period**  
**τ: pulsewidth**

To achieve a white balance, the three chips must be driven with a PWM signal of a particular pulse width. The resulting differences in intensity of the three colors can be additively mixed to produce white light.

To calibrate the display, the particular pulse width must be determined for each color, the value of which is subsequently saved as a preset value. Creation of the PWM signal and saving of the preset value is handled by a microcontroller, for example, the PIC 16F876 from Microchip. A controller is used for each color, and has the tasks of recognizing and compensating for the influence of temperature and aging.

### a) Temperature Compensation

For a color shift due to temperature changes, only the intensity of the red InGaAlP chips needs to be readjusted. In order for the controller to react to temperature changes, a temperature sensor must be employed which is thermally coupled to the LEDs. In this case, an NTC resistor is connected in series with a metal film resistor to form a voltage divider. The output signal of the sensor, which is indirectly proportional to the PCB temperature, is digitized and further processed via an internal A/D converter in the microcontroller.

If the voltage from the sensor varies by a particular amount due to an increase in temperature, the controller reacts by readjusting the LED intensity. This is easily accomplished by simply increasing the pulse width  $\tau$  of the PWM signal which increases the brightness of the red LED. The microcontroller compares the current A/D signal with the previous one, and increases or decreases the pulse width accordingly, in the case where the difference is greater than a particular amount. That is, the microcontroller reacts to relative changes.

## b) Aging Compensation

In the case of aging, compensation is more difficult, since an exact prediction cannot be made about the behavior of the various semiconductor chips over an extended period of operation. Since the intensity of light diodes simply decreases over time, however, aging can be compensated by adjusting the three colors against the preset values for the white balance.

The simplest solution is to deploy a phototransistor which is optically coupled to the LED backlighting via a light guide. The output voltage level of this sensor is proportional to the intensity of the light diodes; that is, the higher the light intensity of the LEDs, the higher the sensor voltage of the phototransistor.

When the backlight is switched on, the controller generates a PWM signal for the red LEDs. The two other controllers switch their outputs to low. The pulse width of this single PWM signal is slowly increased from zero, causing the intensity of the backlight to increase, and thus increasing the output voltage of the phototransistor. The voltage from the photosensor is digitized by an A/D converter in the microcontroller and the current value is compared to the preset value for the white balance.

If the current value is less than the preset value, the controller increases the pulse width which causes an increase in intensity for the red LEDs. When the current value becomes greater than the preset value, the microcontroller stops increasing the pulse width, saves this value, and sets the PWM output to low. The controllers for the other two colors each carry out this same procedure in turn. After the last controller

has finished executing its program, the controllers sequentially switch on the PWM signal with the previously saved pulse width ratios, which leads to a white backlight when the values are summed.

The compensation can be manually initiated by the user or can be automatically scheduled by the controller based on hours of operation.

## Technical Implementation of the Compensation Circuitry

The technical implementation of the compensation circuitry consists of three parts; the Control and Regulation Unit with the PIC microcontrollers, the driver board for driving the LEDs, and the individual backlight which also includes the temperature sensor and photosensor. (Fig. 6).

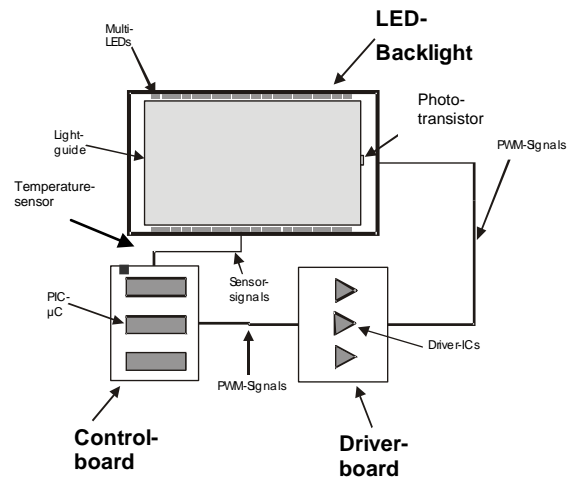

**Fig. 6: Hardware construction for white point stabilization**

### a) Control and Regulation Unit

The sensor signals must be prepared for further processing by the controllers. By means of an integrator, the square wave signal from each phototransistor is

converted to a DC signal which is then supplied to the input pin of the controller.

The microcontrollers form the heart of the Control and Regulation Unit; they process the sensor data and create the corresponding PWM output signal for optimal control of the LEDs.

A voltage regulator is necessary for the supply voltage for the PICs. This is also used as a reference voltage for the A/D converters.

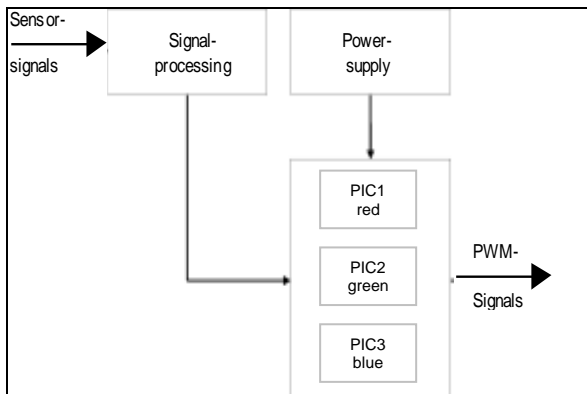

**Fig. 7: Block diagram of the control unit**

**b) Driver Board**

The LED backlighting requires currents in the range of 1.5 A. This cannot be supplied directly from the microcontrollers, however, due to the danger of electrical and thermal overloading. In this case, special driver ICs are used to supply the LEDs with the required current. Controlled from the PWM signal from the PIC, the TLE4242 device from Infineon acts as a constant current source for driving the LEDs with a particular duty cycle.

The driver circuitry is located on a separate board in order to provide thermal isolation from the control board.

**c) LED Backlighting**

The backlight is approximately seven inches in length. The light diodes are soldered to a flexible circuit and couple the light on the front side (above and below) by means of a light guide. With this method, the so-called indirect backlighting is homogeneously distributed in the light guide. Reflectors are located on the back and side surfaces of the light guide which prevent the light from escaping and cause the light to be directed forward in order to minimize damping loss.

The phototransistor SFH 3410 from Osram Opto Semiconductors, which is responsible for aging compensation, is mounted on the side of the light guide. The NTC resistor is thermally coupled with the LEDs on the circuit board.

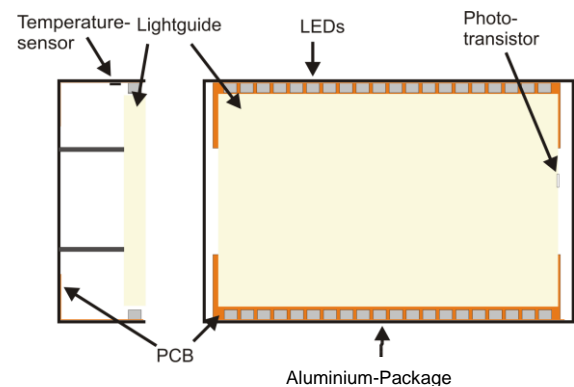

**Fig. 8: LED backlight construction**

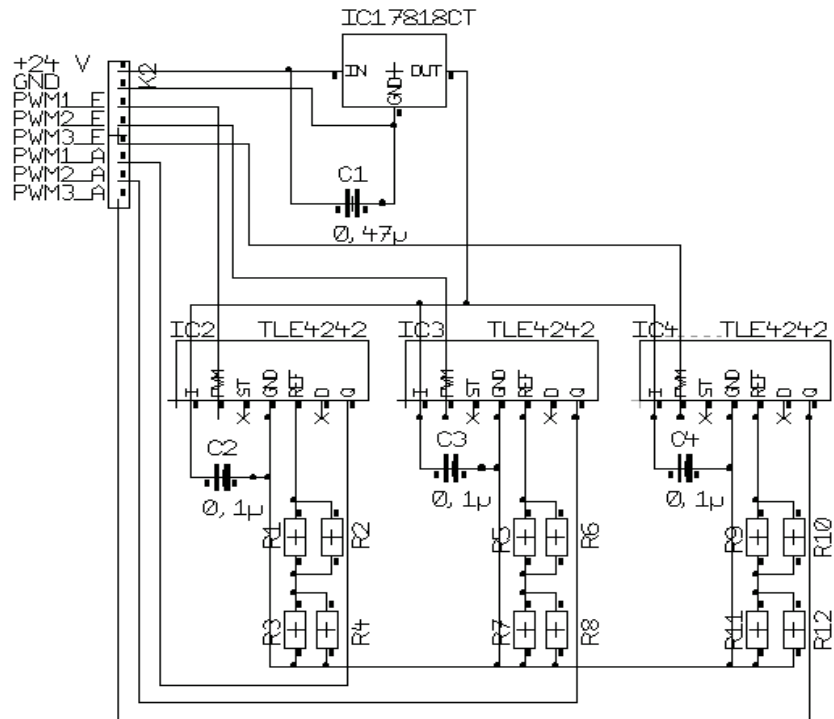

**Fig. 9: Circuit diagram for the driver board**

IC1: voltage regulator HC7818

IC2-4: driver components TLE4242

C1-4: smoothing capacitors

R1-12: resistor network for output current adjustment

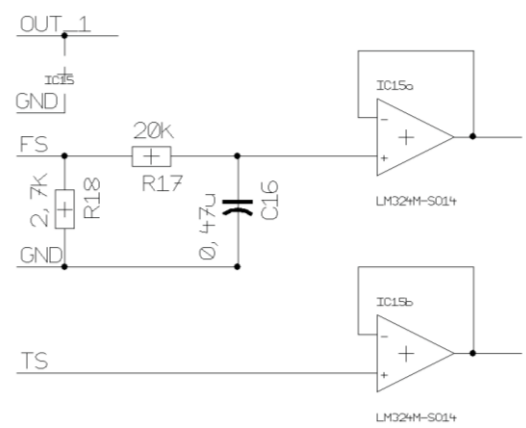
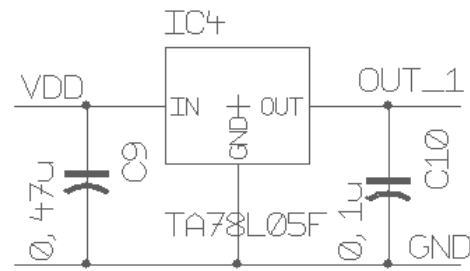
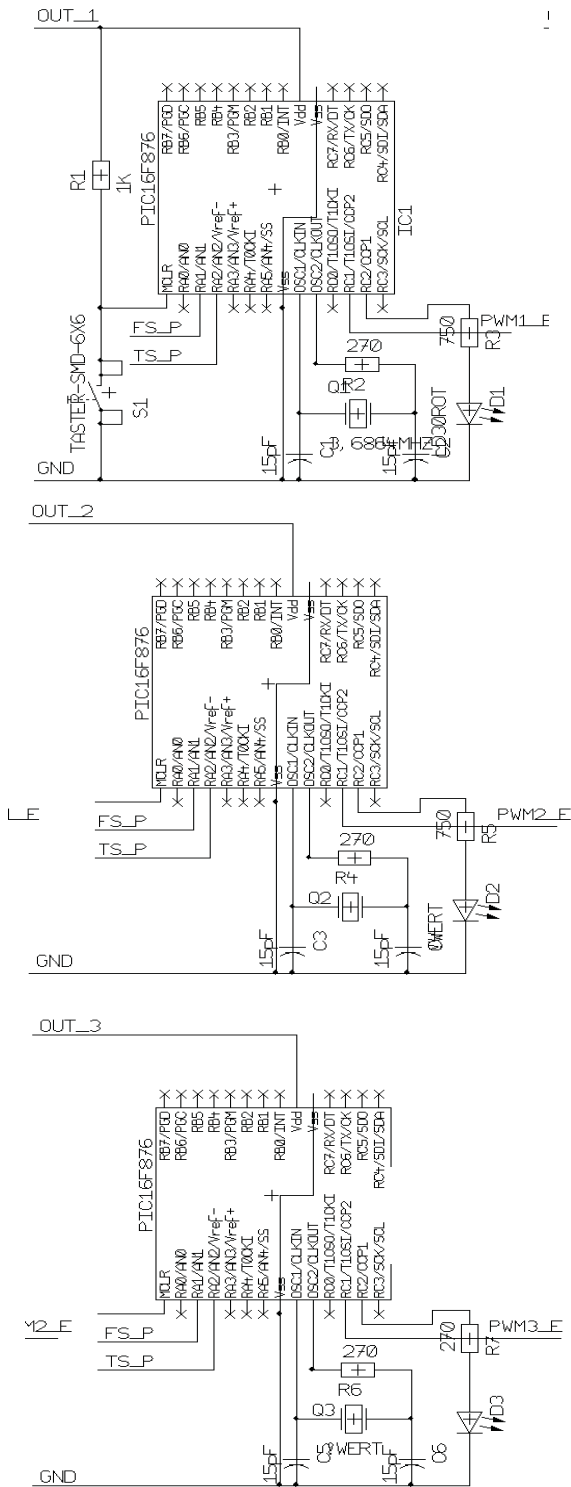

- IC1: PIC1; regulates the red LEDs
- IC2: PIC2; regulates the green LEDs
- IC3: PIC3; regulates the blue LEDs
- IC4: voltage regulator TA78L05
- IC15: op amp LM324, for signal conditioning
- C9-10: smoothing capacitors
- Q1-3: quartz oscillator 3.68MHz
- C1-6: capacitors for the oscillator circuit
- D1-3: control LEDs for the PICs

**Fig. 10: Circuit diagram for the control board**



## Alternatives and Summary

When looking for cost effective alternatives, the use of a single microcontroller containing three PWM modules is a possibility. The 8-bit Controller *Atmega8* from Atmel is especially well suited for this task. This device consists of a RISC in a 28 pin DIP package with three PWM modules and up to 8 A/D converter inputs.

As an alternative to using a phototransistor which detects all three colors simultaneously, an RGB color sensor could be employed. Because it consists of three individual sensors, this would allow detection of temperature as well as aging effects. This is due to the RGB sensor, whose spectrum is exactly matched to that of the LEDs. A change in intensity of one LED color does not produce an effect on the other color ranges of the sensor.

The appearance and functional construction a possible compensation circuit for white point stabilization is strongly dependent on the type of LED.

Although the method described for compensating for aging influences can be transferred to other LED types, temperature compensation requires that the exact temperature characteristics of the light diode must be ascertained. Furthermore, the operating temperature range of the backlight is very important, since this also determines the extent of regulation required.

In all cases, additional applications in this area should utilize a PWM signal for controlling the LEDs, since the linear relationship between pulse width and LED intensity can easily be implemented with a microcontroller.

Author: Raimund Zach

## ABOUT OSRAM OPTO SEMICONDUCTORS

**OSRAM, Munich, Germany is one of the two leading light manufacturers in the world. Its subsidiary, OSRAM Opto Semiconductors GmbH in Regensburg (Germany), offers its customers solutions based on semiconductor technology for lighting, sensor and visualization applications. Osram Opto Semiconductors has production sites in Regensburg (Germany), Penang (Malaysia) and Wuxi (China). Its headquarters for North America is in Sunnyvale (USA), and for Asia in Hong Kong. Osram Opto Semiconductors also has sales offices throughout the world. For more information go to [www.osram-os.com](http://www.osram-os.com).**

## DISCLAIMER

**PLEASE CAREFULLY READ THE BELOW TERMS AND CONDITIONS BEFORE USING THE INFORMATION SHOWN HEREIN. IF YOU DO NOT AGREE WITH ANY OF THESE TERMS AND CONDITIONS, DO NOT USE THE INFORMATION.**

The information shown in this document is provided by OSRAM Opto Semiconductors GmbH on an "as is basis" and without OSRAM Opto Semiconductors GmbH assuming, express or implied, any warranty or liability whatsoever, including, but not limited to the warranties of correctness, completeness,



merchantability, fitness for a particular purpose, title or non-infringement of rights. In no event shall OSRAM Opto Semiconductors GmbH be liable - regardless of the legal theory - for any direct, indirect, special, incidental, exemplary, consequential, or punitive damages related to the use of the information. This limitation shall apply even if OSRAM Opto Semiconductors GmbH has been advised of possible damages. As some jurisdictions do not allow the exclusion of certain warranties or limitations of liability, the above limitations or exclusions might not apply. The liability of OSRAM Opto Semiconductors GmbH would in such case be limited to the greatest extent permitted by law.

OSRAM Opto Semiconductors GmbH may change the information shown herein at anytime without notice to users and is not obligated to provide any maintenance (including updates or notifications upon changes) or support related to the information.

Any rights not expressly granted herein are reserved. Except for the right to use the information shown herein, no other rights are granted nor shall any obligation be implied requiring the grant of further rights. Any and all rights or licenses for or regarding patents or patent applications are expressly excluded.