

Driving the Advanced Power TOPLED

Application Note

Introduction

LEDs are currently used in many application areas. In the automobile sector, nearly all dashboards utilize LEDs for backlighting. For new application areas which require a higher light output, even more efficient and powerful LEDs are needed. Brake lights, turn signals and fog lights, for example, require powerful LEDs in order to fulfil statutory regulations.

Every application requires the selection of an appropriate LED. The Advanced Power TOPLED (APT) serves to complement the Power TOPLED and Golden Dragon power components. With a maximum power consumption of approximately 0.5W and high optical efficiency, this package fills the light output gap between the Power TOPLED and the Golden Dragon (Figure1).

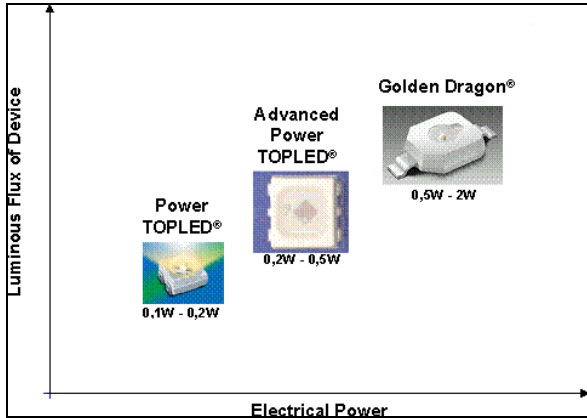

Figure 1: Comparison of the power consumption of different LED packages

This application note describes the electrical characteristics of the Advanced Power TOPLED along with various electrical simulations.

Response Curve of the Advanced Power TOPLED

Above a certain threshold voltage, the LED is conductive and exhibits a steep $I_f - V_f$ response curve (see Figure 2). In the reverse direction, the LED blocks the flow of current.

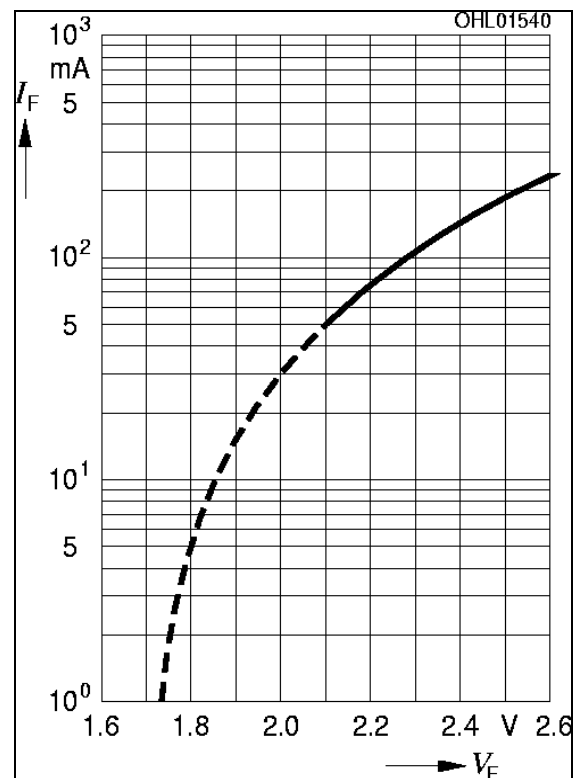

Figure 2: Typical forward response curve for the LA G67F at $T_a = 25^\circ\text{C}$ (see LA G67F datasheet)

For comparison, the minimum and maximum response curve for Voltage Group 4A of the LA G67F are shown in the following figure (Figure 3).

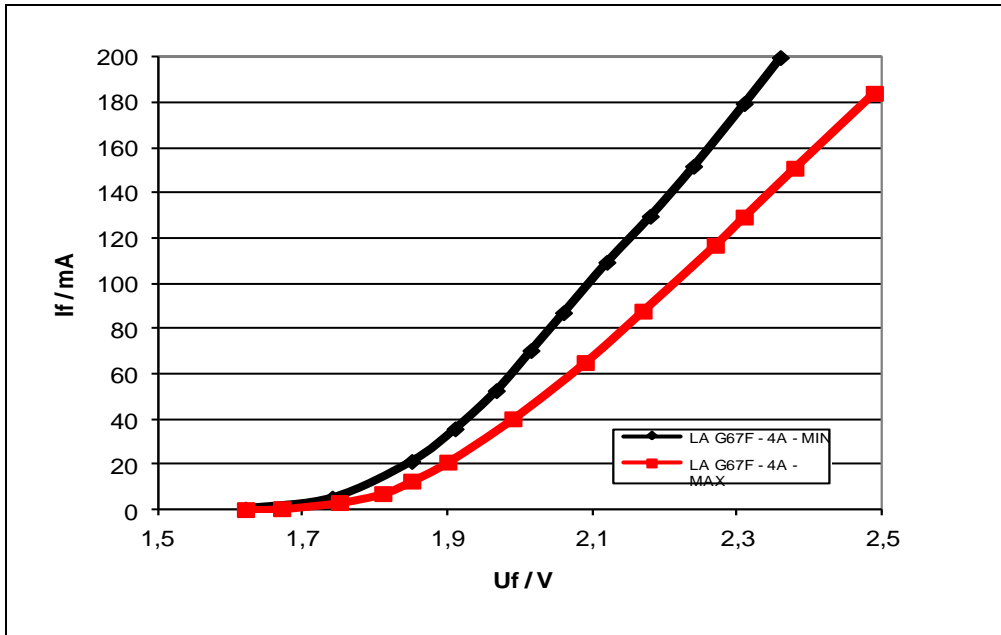

Figure 3: Comparison of minimum and maximum response curve of the LA G67F-4A, simulated with PSpice

The following figure (Figure 4) shows the comparison of an Advanced Power TOPLED (LY G67B) and a Power TOPLED (LY E67B) in HOP2000 chip technology, simulated in PSpice.

Both response curves were simulated at room temperature for LEDs from Voltage Group 3 (typical response curve). In comparison to the Power TOPLED, the APT exhibits a clearly steeper response curve.

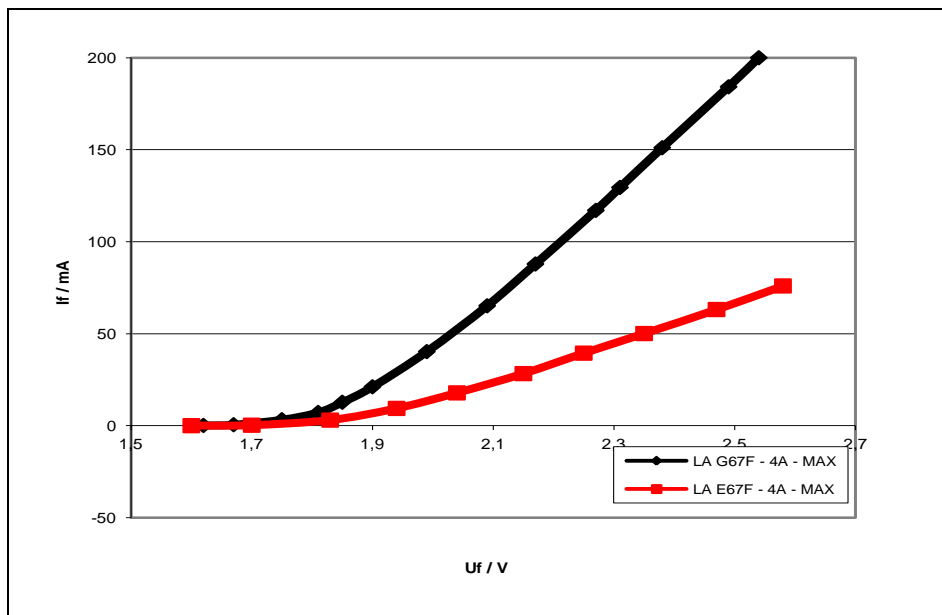

Figure 4: Comparison of the Advanced Power TOPLED (LA G67F-4A-MAX) and Power TOPLED (LA E67F-4A-MAX).

It can be seen that the response curve for the APT is steeper than the one of the Power TOPLED.

Vf-Grouping of the Advanced Power TOPLED

The selection of voltage groups for the Advanced Power TOPLED is similar to that of the Power TOPLED, with a grouping current of **140mA**, however.

The LA G67F and the LY G67B are divided into the following voltage subgroups:

- Voltage Subgroup 3B: 2.05V – 2.20V
- Voltage Subgroup 4A: 2.20V – 2.35V
- Voltage Subgroup 4B: 2.35V – 2.50V
- Voltage Subgroup 5A: 2.50V – 2.65V

Driving the Advanced Power TOPLED

When driving the APT, care should be taken that the maximum permissible operating conditions are not exceeded. First of all, it is important that the forward current does not exceed a constant maximum of 200mA throughout the entire input voltage range (for the LA G67F and the LY G67B). This should be insured with appropriate driver circuitry. Secondly, the maximum junction temperature of 125°C must not be exceeded. This must be insured with appropriate thermal management (see also the application note: “Thermal Management of SMT LEDs”).

This application note only discusses the electrical characteristics of the APT; the thermal characteristics are not discussed. Details of the thermal characteristics can be obtained from the above-mentioned application note.

For the following simulations, these assumptions are always valid: The simulation results are immediately ascertained after power-on, at room

temperature. No thermal effects are considered. Corresponding to a typical battery voltage within the automobile sector, an input voltage of 13.5V (minimum 9V, maximum 16V), is chosen. Analogously, the results can also be transferred to other application areas by using other input voltages.

Serial Connection with the Advanced Power TOPLED

In a further simulation, the behavior of voltage subgroup 4A was investigated. The resistance in each path was chosen such that a current of 140mA was supplied, corresponding to the middle response curve of voltage subgroup 4A (Figure 5).

In order to simulate the worst case, four LA G67F LEDs from the lower edge of subgroup 4A were used in the left path (LA G67F-4A-MIN). In the right path, four LA G67F LEDs from the upper edge of subgroup 4A were used (LA G67F-4A-MAX).

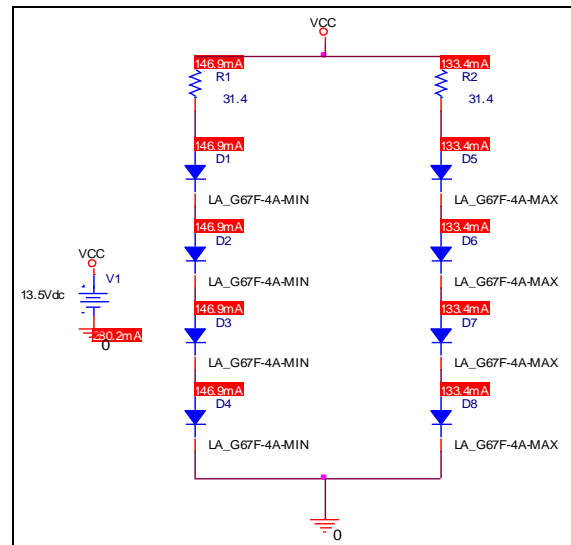

Figure 5: Serial connection for the LA G67F: left path: Voltage Group 4A Minimum, right path: Voltage Group 4A Maximum

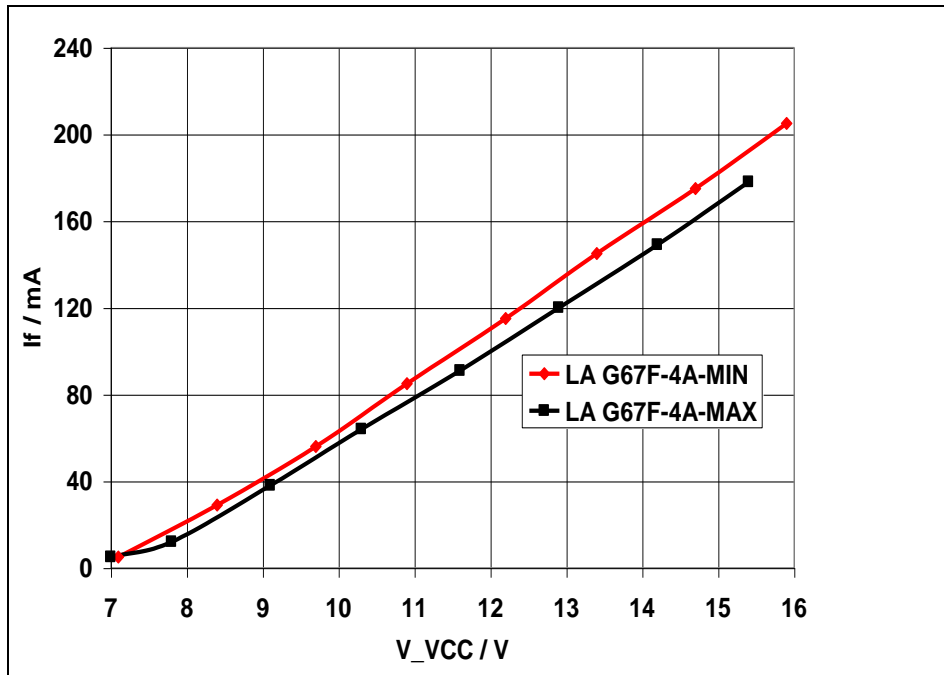

Figure 6: Current through D1 and D5 vs input voltage

The LEDs from the lower edge of voltage subgroup 4A draw a current of around 147mA, while the LEDs from the upper edge of voltage group 4A draw a current of around 133mA at a supply voltage of 13.5V. In the above diagram (Figure 6), the behavior of the two paths is shown for the entire input voltage range. The slight spreading is due to the differences of the minimum and maximum response curves.

Matrix Connection with the Advanced Power TOPLED

In the matrix connection, the same LEDs were used as with the serial connection. In contrast however, the LEDs were connected to each other with a cross connection. In addition, only one series resistor was used for the entire circuit. This series resistor was chosen such that a typical current of about 140 mA was present at each LED.

In comparison, a matrix connection for a single voltage subgroup was simulated, as is the case for the LA G67F (Figure 7).

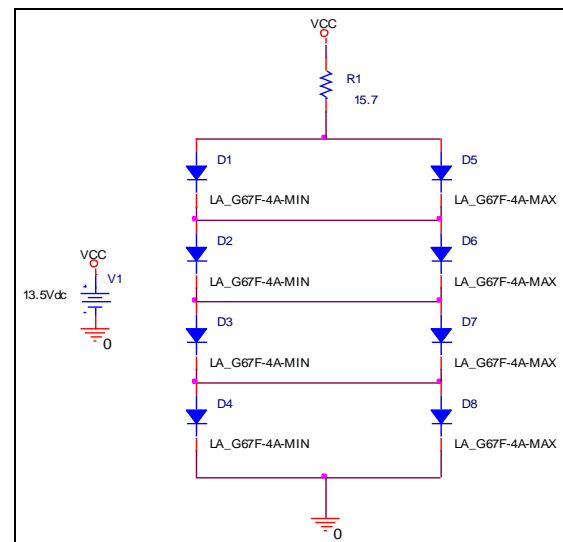

Figure 7: Matrix connection with the LA G67F: left path: Voltage Group 4A Minimum, right path: Voltage Group 4A Maximum

In this case also, the resistance was chosen such that the current through each path was exactly 140mA, corresponding to the middle response curve of the voltage subgroup 4A.

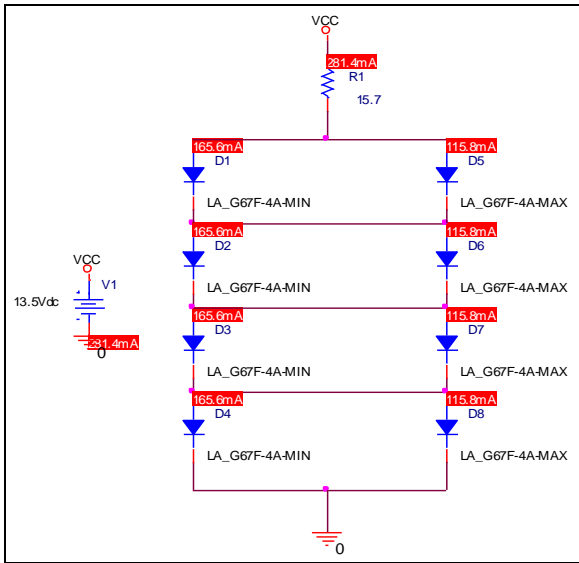

Figure 8: Current distribution at a battery voltage of 13.5V in the matrix connection

In order to demonstrate the worst case once again, LEDs from the upper edge (LA G67F-4A-max) and the lower edge (LA G67F-4A-min) of voltage group 4A were employed (Figure 8).

This simulation shows a distinct difference between the maximum current value of 165mA and the minimum current value of 115mA at a voltage of 13.5V (Figure 9).

For LEDs with the lower forward voltage, the maximum current of 200mA is exceeded for battery voltages greater than 14.8V.

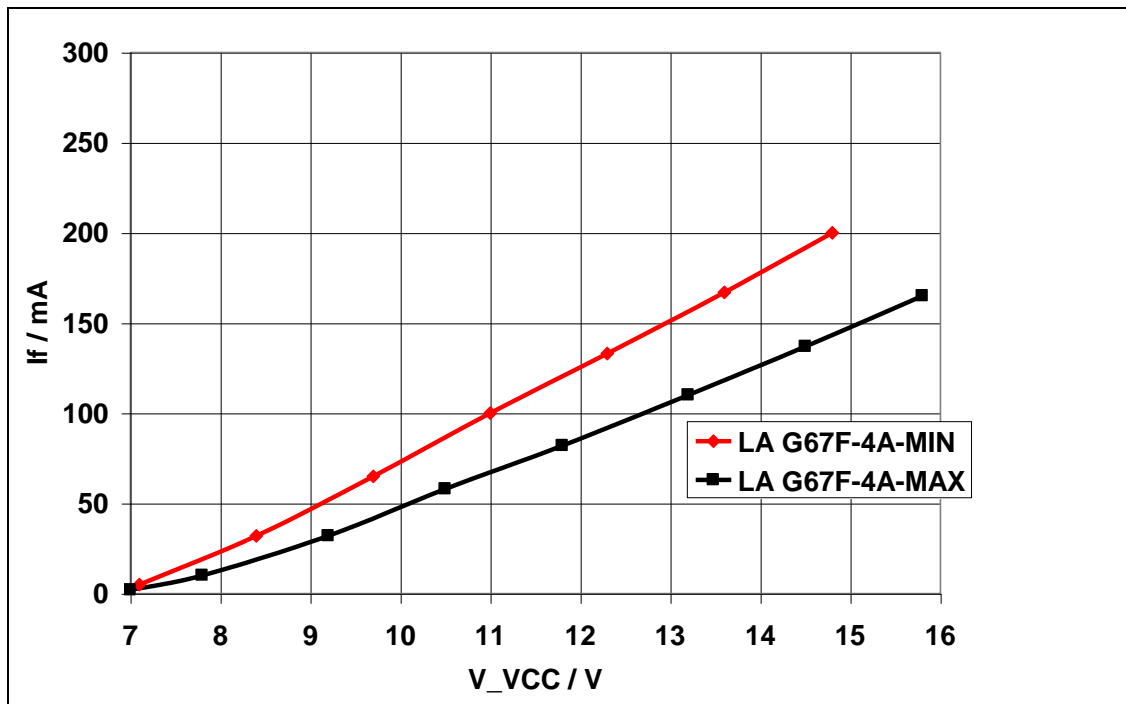

Figure 9: Current through D1 and D5 vs input voltage:

Overdrive Protection

In addition to the limiting resistors and the obligatory reverse protection diode, a PTC (positive temperature coefficient) resistor can be connected in series with the two LED paths.

The PTC resistor has a positive temperature coefficient; that is, the resistance of the component becomes greater with increased temperature. The resistance of the PTC increases when the ambient temperature increases, or when the LEDs are driven at higher levels, resulting in a warming of the LEDs themselves, and thus a warming of the PTC. As the resistance of the PTC increases, the current through the circuit is reduced. In this way, the current through the LEDs can be limited.

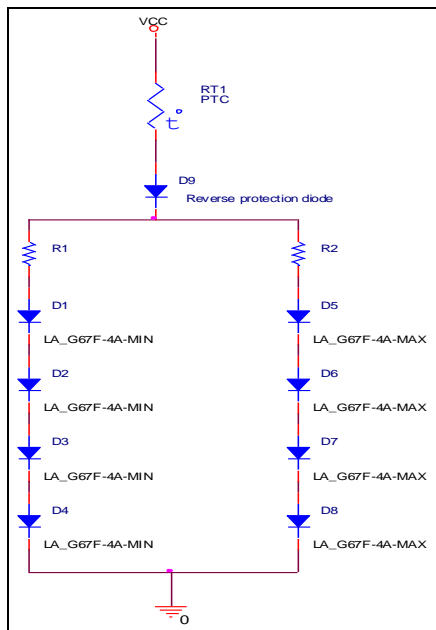

Figure 10: Serial connection with a PTC resistor

Driving the Advanced Power TOPLED with a Current Driver

An elegant solution for regulating the current through a series of LEDs is to use an

appropriate driver device. In the following example, the TLE 4242G from Infineon was used for current regulation (see Figure 11).

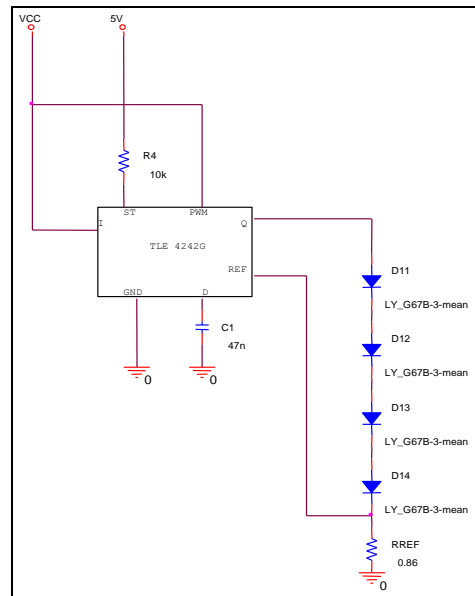

Figure 11: Current regulation with the TLE 4242G. The above circuit was not simulated; after construction of the circuit, the measurement data was recorded and displayed in the following diagram.

The circuit was designed such that the current through the Advanced Power TOPLEDs at a nominal battery voltage of 13.5V is approximately 200mA.

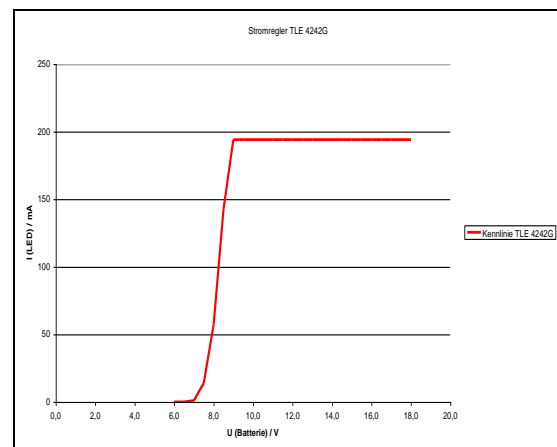

Figure 12: LED current in relation to supply voltage with the TLE 4242G

Above a battery voltage of about 6V, the current begins to flow through the LEDs. At around 9V, ~190mA of current flows through the APTs. This current remains constant throughout the entire battery voltage range of 9-16V. The current first collapses at a voltage below 9V. At lower supply voltages, however, an increase in forward voltage leads to a breakdown of current. This must therefore be taken into account if the LEDs are to be illuminated at lower supply voltages.

The advantage of using a current regulator as opposed to driving the LEDs with resistors can be seen here. The current through the LEDs remains constant over the entire voltage range of the battery. More importantly, at a nominal battery voltage, the current through the LED amounts to practically the maximum value of 200mA. The LED can therefore be fully driven at a nominal battery voltage, whereas the LED with a series resistor must be powered with considerably less current in this case. Since

a higher current level also leads to a higher intensity level, this permits the same number of LEDs to produce more light. On the other hand, current regulation permits one to achieve the same light intensity with fewer LEDs than that of a resistive circuit.

Conclusions

The Advanced Power TOPLED can be driven with a resistor if the maximum current throughout the entire supply voltage range and the maximum permissible junction temperature are not exceeded. It is recommended, however, that the circuitry utilize individual serial paths for diode illumination, since the current distribution from a pure matrix circuit can lead to overdriving the LEDs.

The use of a current regulator has a positive effect on LED performance.

Author: Markus Hofmann

ABOUT OSRAM OPTO SEMICONDUCTORS

OSRAM, Munich, Germany is one of the two leading light manufacturers in the world. Its subsidiary, OSRAM Opto Semiconductors GmbH in Regensburg (Germany), offers its customers solutions based on semiconductor technology for lighting, sensor and visualization applications. Osram Opto Semiconductors has production sites in Regensburg (Germany), Penang (Malaysia) and Wuxi (China). Its headquarters for North America is in Sunnyvale (USA), and for Asia in Hong Kong. Osram Opto Semiconductors also has sales offices throughout the world.

For more information go to www.osram-os.com.

DISCLAIMER

PLEASE CAREFULLY READ THE BELOW TERMS AND CONDITIONS BEFORE USING THE INFORMATION SHOWN HEREIN. IF YOU DO NOT AGREE WITH ANY OF THESE TERMS AND CONDITIONS, DO NOT USE THE INFORMATION.

The information shown in this document is provided by OSRAM Opto Semiconductors GmbH on an “as is basis” and without OSRAM Opto Semiconductors GmbH assuming, express or implied, any warranty or liability whatsoever, including, but not limited to the warranties of correctness, completeness, merchantability, fitness for a particular purpose, title or non-infringement of rights. In no event shall OSRAM Opto Semiconductors GmbH be liable - regardless of the legal theory - for any direct, indirect, special, incidental, exemplary, consequential, or punitive damages related to the use of the information. This limitation shall apply even if OSRAM Opto Semiconductors GmbH has been advised of possible damages. As some jurisdictions do not allow the exclusion of certain warranties or limitations of liability, the above limitations or exclusions might not apply. The liability of OSRAM Opto Semiconductors GmbH would in such case be limited to the greatest extent permitted by law.

OSRAM Opto Semiconductors GmbH may change the information shown herein at anytime without notice to users and is not obligated to provide any maintenance (including updates or notifications upon changes) or support related to the information.

Any rights not expressly granted herein are reserved. Except for the right to use the information shown herein, no other rights are granted nor shall any obligation be implied requiring the grant of further rights. Any and all rights or licenses for or regarding patents or patent applications are expressly excluded.